



## ***Our Equipment Works Harder So You Don't Have To***

The Biro Models VTS-43 and VTS-44 are the tools you need to create the value added, marinated entrees your customers demand. With the VTS-43 and VTS-44 you can marinate most meats and fish in less than 20 minutes, so you can make those value added products in a minimum amount of time. Vacuum marinating distributes the marinade throughout the product, so you get full flavor in every bite. It also adds water and tenderizes the product, so the product cooks faster and is juicy and flavorful. Shelf life is extended, and freshness, color, and eye appeal are enhanced, so you'll see these products fly off the shelf and your profits jump. The VTS-43 and VTS-44 are incredibly easy to use, too.

It only takes 5 minutes to load the product, water, and marinade, and it runs for 20 minutes while you do something else. When a batch is done, you only need 5 minutes to empty the drum and wash it out, and you're ready to do another batch. For even more productivity, the VTS-43 and VTS-44 has twin 20 pound (9.09 kg) drums so you can do two batches at the same time. Best of all, the low machine cost and big boost to your profit margins mean a return on your investment measured in weeks.



VTS-43  
REMOTE PUMP NOT SHOWN

**VTS-43/44**



*Stands alone for quality  
and value since 1921*

## SPECIFICATIONS

**MODEL** VTS-43 VACUUM MARINATING TUMBLER W/REMOTE PUMP.  
VTS-44 VACUUM MARINATING TUMBLER W/SELF CONTAINED PUMP.  
**ELECTRICAL** 1/25 HP (44 W), 115 VOLTS, 60 HZ, 1 PHASE, 5' CORD AND 3-PRONG PLUG.  
**CONSTRUCTION** STAINLESS STEEL EXCEPT THE WHEELS AND LID GASKETS.  
**MOTORS**

VTS-43

MOTOR	HP	KW	VOLTS	AMPS	HERTZ	PHASE	CODE
DRIVE	1/25	.03	115	.61	60	1	STD
PUMP	1/8	.09	115	4.20	60	1	STD

VTS-44

MOTOR	HP	KW	VOLTS	AMPS	HERTZ	PHASE	CODE
DRIVE	1/25	.03	115	.61	60	1	STD
PUMP	1/8	.09	115	4.20	60	1	STD
DRIVE	1/25	.03	220	.31	60	1	EC
PUMP	1/8	.09	220	2.10	60	1	EC
DRIVE	1/25	.03	220	.25	50	1	EC
PUMP	1/8	.09	220	2.00	50	1	EC

STD= STANDARD

EC=EXTRA COST

**DRUM CAPACITY** TWIN 20 POUND (9.1 KG) DRUMS EACH, MAXIMUM, 15 LBS (6.8 KG) OPTIMUM.  
**DRIVE MOTOR** 1/25 HP (44 W).  
**VACUUM PUMP** 1/8 HP (138 W) WITH FILTER VTS-43.  
1/8 HP (138 W) WITH EXTERNAL FILTER ON CASE VTS-44  
**TUMBLE SPEED** APPROXIMATE 8 RPM.  
**STANDARD FEATURES** 5' CORD AND 3 PRONG PLUG, 115-60-1  
5' CORD, NO PLUG, 220-60-1 AND 220-50-1  
OPERATING AND SAFETY MANUAL.  
**OPTIONS (EC)** VARIABLE SPEED (0-14), TUMBLER CART; 220-60-1 & 220-50-1 VTS-44 ONLY, WOOD BOX.  
**CERTIFICATION** U.L. AND N.S.F. ON VTS-43; NSF ON VTS-44.  
**WEIGHT** VTS-43 – 63 LBS. (28.6 KG) CARTON #1; 18 LBS. (8.2 KG) CARTON #2; 29 LBS. (13.1 KG) CARTON #3.  
UNCRATED: 86 LBS. (39 KG).  
VTS-44 – 78 LBS. (35.4 KG) CARTON #1; 21 LBS. (9.5 KG) CARTON #2.  
UNCRATED: 86 LBS. (39 KG).  
**DIMENSIONS PACKED** VTS-43 CARTON 1: 40" (1015 MM) X 19" (483 MM) X 12" (304 MM).  
CARTON 2: 13" (330 MM) X 10" (254 MM) X 12" (304 MM).  
CARTON 3: 15" (381 MM) X 15" (381 MM) X 22" (559 MM).  
VTS-44 CARTON 1: 37" (939 MM) X 19" (483 MM) X 11" (279 MM).  
CARTON 2: 14" (356 MM) X 14" (356 MM) X 22" (559 MM).

DIMENSIONS  
VTS-43 & VTS-44

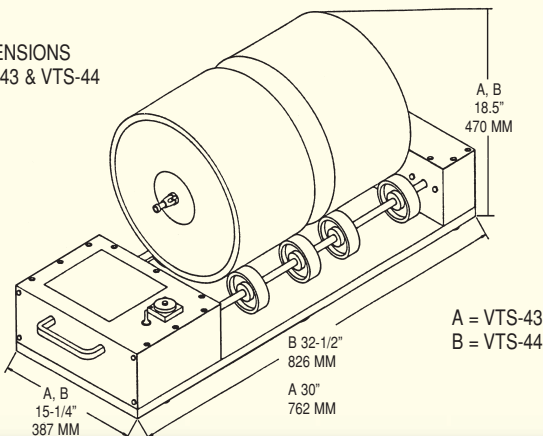

**THE BIRO MANUFACTURING COMPANY**  
1114 WEST MAIN STREET  
MARBLEHEAD, OH 43440-2099 U.S.A.  
Phone: (419) 798-4451  
Fax: (419) 798-9106  
<http://www.birosaw.com>  
[sales@birosaw.com](mailto:sales@birosaw.com)

ITEM NO.: LIT VTS-43-44-281  
FORM NO.: Md VTS-43-44-281-9-06-4

Service is available from over 245 locations worldwide